

PALLET LIFTER

BETTER MANUAL HANDLING

TECHNICAL SPECIFICATIONS

NOTE: EVERYTHING CAN BE CUSTOMIZED FOR YOUR NEEDS

- > LIFT CAPACITY: 1000 KG
- > TRAVEL: 900
- > MIN. FORK HEIGHT: 85 MM.
- > MAX FORK HEIGHT: 985 MM.
- > FORK LENGTH: 1185 MM.
- > FORK WIDTH: 840 MM.
- > TOTAL LENGTH: 1685 MM.
- > TOTAL WIDTH: 1000 MM.
- > TOTAL HEIGHT: 1620 MM.
- > TILT CAPACITY TSL9: 750 KG
- > TILT DEGREES TLS9: 40 DEGREES
- > POWER SUPPLY: 3x400 V/50 HZ+PE
- > CE CERTIFIED
- > AVAILABLE IN RAL COLOURS, GALVANIZED OR STAINLESS STEEL (NOTE: 500 KG CAP.)
- > RUNS 10 LIFTS PER HOUR 8 HOURS A DAY (FULL TRAVEL)
- PLEASE INQUIRE FOR INTENSIVE USE



The TRANSLYFT pallet lifter is a convenient, ergonomic and safe way of handling your goods while also relieving your employees as they avoid heavy lifting and bending in the back. The pallet lifter is ideal for palletizing / depalletizing and provide leg and foot space from three sides, which provide great accessibility and optimizes workflows.

The pallet lifter has very low fork height (app. 85 mm) so no pit is required, integrated power unit and is fitted with wheels so it can be easily moved. A pallet or container can be placed directly on the pallet lifter with pallet truck or forklift.

The Pallet lifter can be equipped with tilt for a better and more ergonomic work position. Find more information at www.translyft.com/uk/



Translyft pallet lifters are ideal for use in compensation for differences in work levels, in particular when used with palletised loads.



The tilt function reduces the reach distance for the operator. The forks can be tilted up to 40 degrees (both left and right).

TYPE / CAPACITY KG	TRAVEL MM.	MIN. FORK HEIGHT MM.	MAX FORK HEIGHT MM.	TOTAL HEIGHT MM.	FORK WIDTH MM.	TOTAL WIDTH MM.	FORK LENGTH MM.	TOTAL LENGTH MM.	LIFTING TIME SEC.
TSL9 - 1000	900	85	985	1620	840	1000	1185	1685	20
TSLN-9 (1000)*	900	85	985	1620	840	1000	1185	1685	20
TSL (1000)**	900								20

* With tilt. Tilt capacity: 750 kg. Tilt degrees: 40

** the TLS is without supporting legs and forks.

The mast is fitted with a bottom flange for float fixing.

Capacity

Highest load capability (when loaded correctly)

Travel

Travel from closed height to top position

Min. fork height

Fork height at lowest position

Max fork height (1)

Fork height at top position

Total height

Height of machine in top position

Fork width (2)

Width between forks

Total width (3)

Width between widest points

Fork length

Length of forks

Total length (4)

Total length of machine

Lifting time

Time in sec. to top position

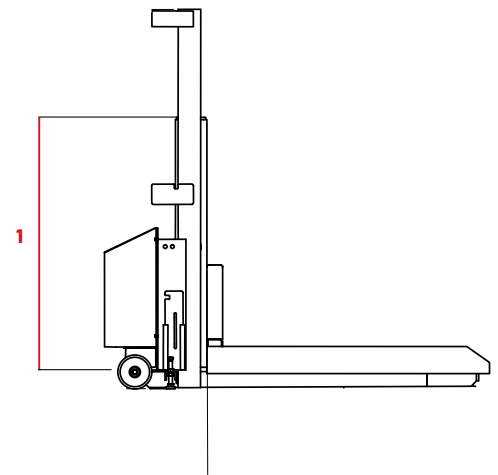
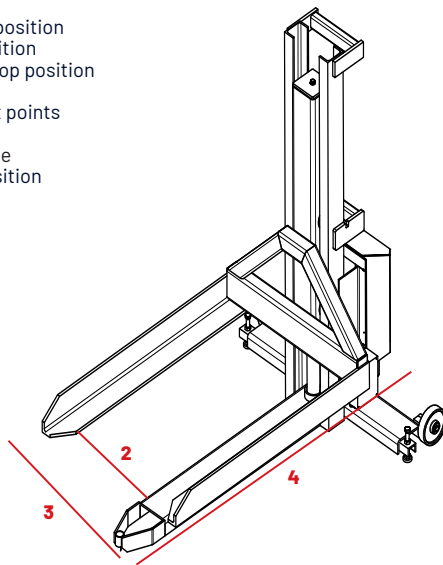

Have any questions about dimensions or features? Please call us at 0870 904 7775 or find more information at www.translyft.com